

125, 150 & 200 H.P.

Sullivan

Palatek®

“The Ultimate Performance Rotary Screw Air Compressor”



***Proven performance
with exceptional design***

Sullivan Palatek®

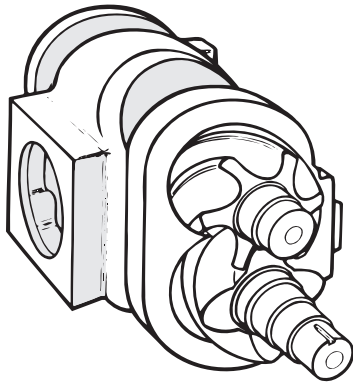

The advantages of owning a Sullivan-Palatek Rotary Screw Air Compressor.

Sullivan-Palatek provides low maintenance, high performance and one of the most reliable air ends in the industry.*

Our design features advanced profile rotary screws that provide improved efficiency. Operating costs are significantly reduced because compressors can be sized to desired operating conditions.

Standard Features

Electric Motor

230/460 volt (125-150-200 H.P.), Nema, T-frame, C-face, open drip proof squirrel cage induction type.*

Motor Starter

460 volt (125-150-200 H.P.), full voltage magnetic starter with 110 volt controls, solid state circuit breaker primary and secondary protection, Nema-1 enclosure, UL, ETL listed and three phase overload with reset and phase protection. Other voltages available. Cooling fan protected by overload relay. Soft Start Starters, Solid State Starters, Wye Delta Starters and Variable Frequency Drives with Micro Processor Control are available upon request.

Separator Tank

ASME coded 200PSIG tank, relief valve, minimum pressure/check valve and high efficiency replaceable oil separator element. Flexible stainless steel braided discharge pipe.

“The Ultimate Performance R

Fluid Fill & Level Elbow

One piece fluid fill elbow and level indicating sight glass. Vented cap for pressure release when filling.



Air Intake Filter

Oversized dry type, with replaceable element.

Inlet/Check Valve

One piece housing for performance and com

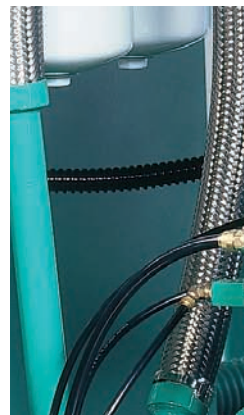

Protective Devices

Class 20 Solid State overload relay, high air temperature, high discharge temperature, high pressure shutdown switches are standard.

Anti-restart pressure switch prevents starting while air compressor is pressurized. Anti-reversing control and unload start are also standard.

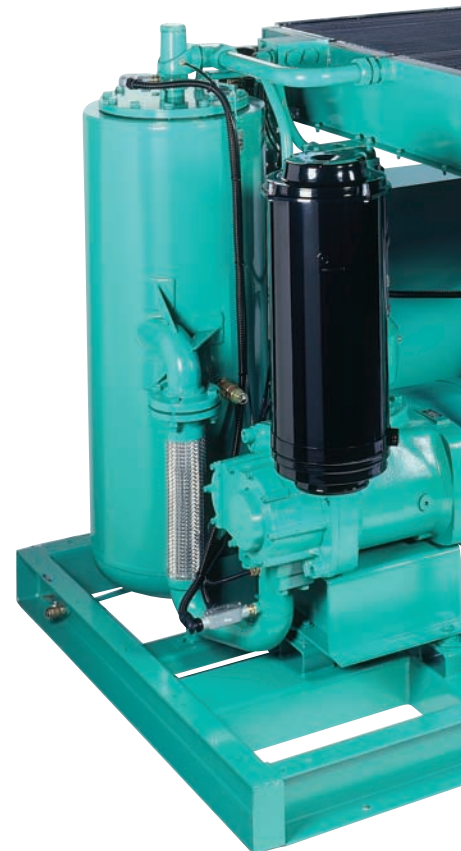

125, 150

*Air End Warranty, 2 years. Extended 5-year Superior Platinum Warranty with purchase of genuine Sullivan-Palatek parts and fluids. Description, Specifications and Pictures represented in this brochure may vary from actual equipment purchased.

Rotary Screw Air Compressor

ith

dependable
plete modulation.



Coupling & Drive

Compressor is flange mounted to motor C-face for positive alignment and direct driven by zero maintenance coupling. The coupling element has a 1 year warranty.*



150/250 H.P. SHOWN



& 200 H.P.

Controls

Full modulation, electronic control, for smooth lowest possible no load power. Automatic Start/Stop with timed shut-off, or constant run selection.

Instrumentation, Optional

Line pressure gauge, discharge pressure gauge, hour meter, temperature gauge, oil filter and separator element differential gauges.

Acoustical Enclosure, Optional

Easily removable panels for accessibility and maintenance. Coated acoustical 2 inch material for easy cleaning and quieter package.

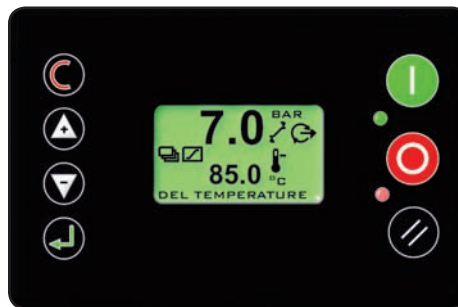

Micro Processor

Easily read output, includes English, German and Spanish languages.

Dual Oil Filter

Large capacity spin on type filters, mounted strategically for ease of maintenance.



STANDARD PERFORMANCE MODELS



5, 7.5 & 10 H.P.



15 & 40 H.P.



40, 50 & 60 H.P.



75 & 100 H.P.

SPECIFICATIONS

Model	125UD	150UD	200UD
Drive Motor (HP)	125	150	200
Fan Motors (HP)	5	5	5
Sump Capacity (GAL)	25	25	25
Discharge (Inches)	2	2	2
Length (Inches)	96	96	96
Width (Inches)	58	58	58
Height (Inches/open)	64	64	64
Height (Inches/enclosed)	67	67	67
Weight (LBS)	3900	4025	4535
Weight (enclosed)	4475	4600	5110

Sold and Serviced By:

ALL DIMENSIONS SHOWN IN INCHES.

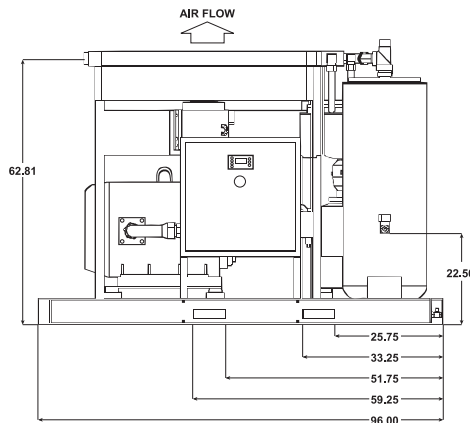

125, 150 & 200 HP

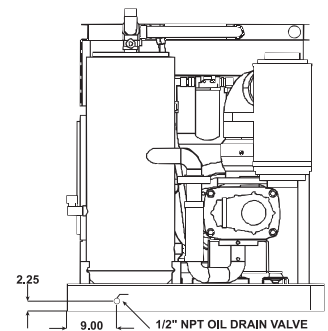

125, 150 & 200 HP

